

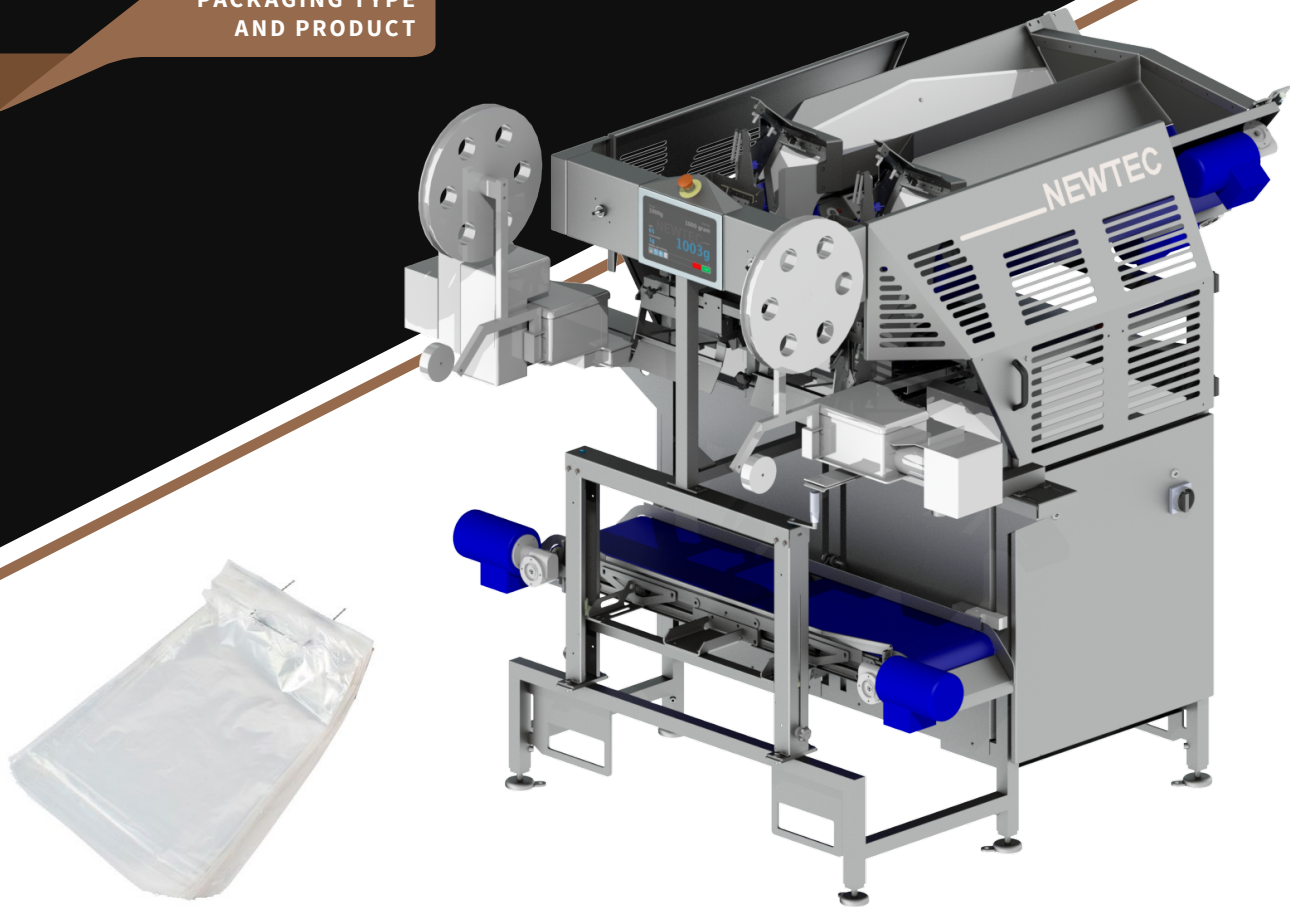

NEWTEC PACKING MACHINE PEB61

CUSTOMISED
ACCORDING TO
PACKAGING TYPE
AND PRODUCT



Versatile packing solutions

Advantages

- High Capacity: Up to 50 bags per min. (2x25 bags)
- Special infeed for large citrus
- Customised according to packaging type and product
- Reliable and easy to maintain
- WebServices available for remote servicing and for capturing production data
- MachineLink enabled – from only one touchscreen, either on our weighing machine or our packing machine, model PEB61, recipe change and start/stop for both machines is possible

Application

Specially designed for citrus packed in wicketed bags:

- **Citrus • Similar fruits**

Prepared for a Kwik lok closing unit



WEBSERVICES AVAILABLE
FOR REMOTE SERVICING

YOUR ADVANTAGES

- Easy access for cleaning and service
- Gentle handling of large portions
- V-belt to stream product into the bag
- Easy refill of bags during operation
- Integrated touchscreen



PREPARED
FOR A KWIK LOK
CLOSING UNIT

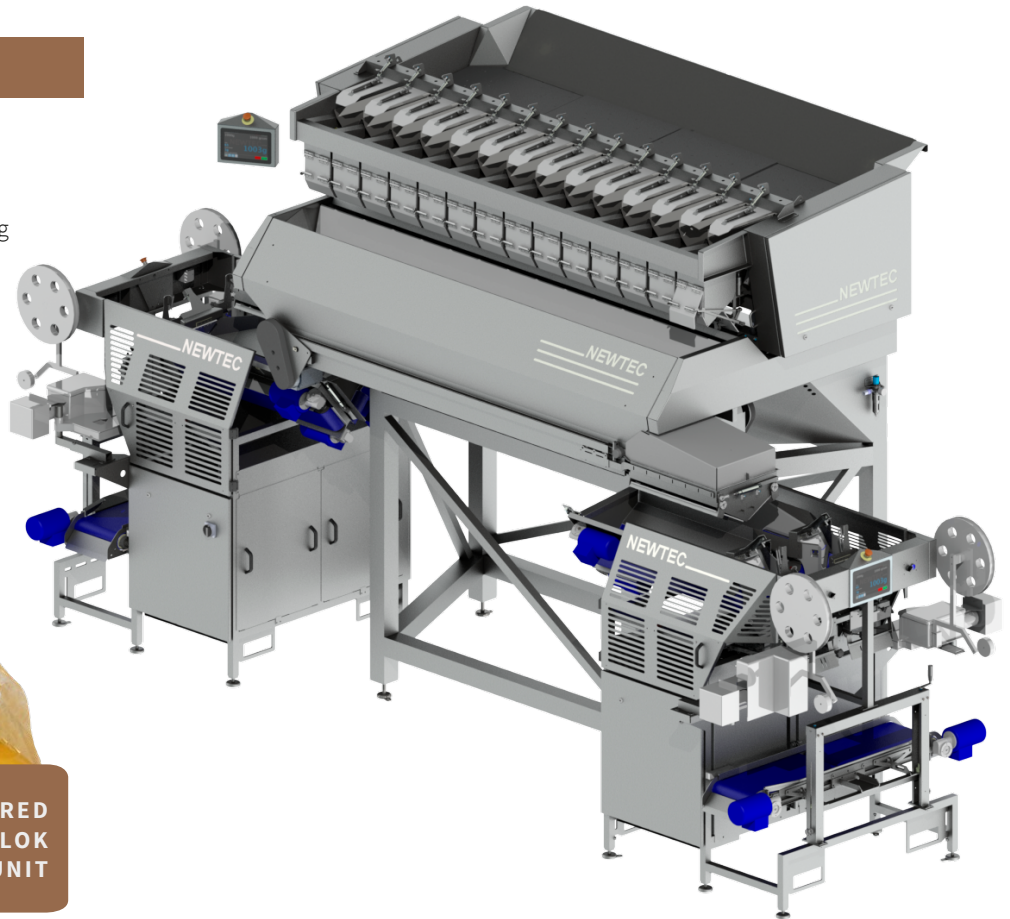

Newtec solution for citrus with our weighing machine, model 4014XB1

PACKING MACHINE FOR WICKETED BAGS

NEWTEC SOFTWARE

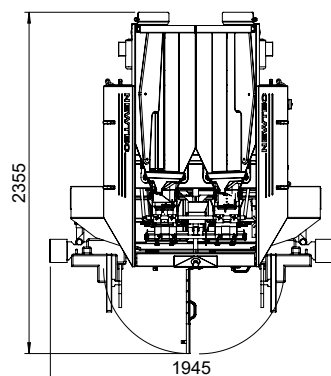
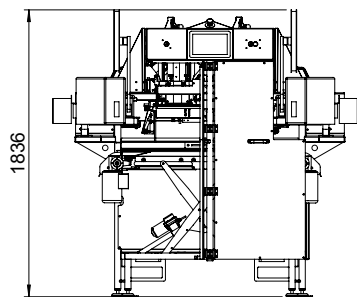

Speed	Up to 50 bags per min. (bag size or weight)
Capacity	Weight up to 10 kg
Material	According to the EU rules on food contact materials
Air requirement	
Connection	3/8"
Min. pressure	6 bar (0.6 Mpa)
Consumption	260 NL/min.
Electrical requirement	3x230 VAC or 3x400 VAC (N) PE 50/60 Hz 2.5 kW
Environment	5°C–40°C
Weight	510 kg

- Intuitive user interface
- Informative and upgradable
- Same user interface on all Newtec weighing and packing machines

